

Lock Handle

for Andersen® Gliding Windows



INSTALLER: Please leave this guide with the building owner to file for future reference.

Your Andersen product has been furnished with a service handle for installation purposes only. To install finished hardware, follow instructions below. For ease of installation and continued enjoyment of your Andersen product, please read and follow this Instruction Guide completely. If your abilities do not match this procedure's requirements contact an experienced contractor. You may direct any questions about this or other products to your local Andersen dealer. Andersen dealers can be found in the Yellow Pages under Windows. Thank you for choosing Andersen.

NOTICE

Unit must be in unlocked and open position before hardware is applied.

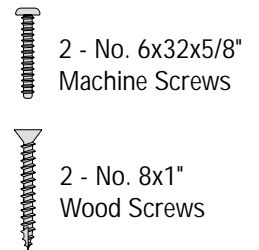
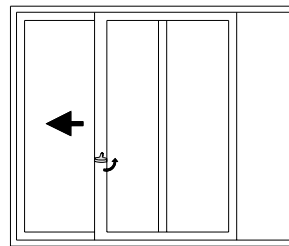

1. Position handle in the "OPEN" position as shown. Lift and rotate escutcheon plate to expose screwholes.

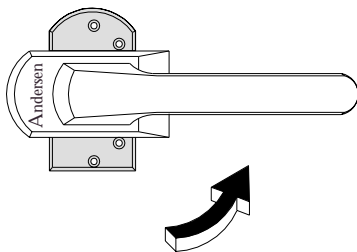

2. Align handle assembly over locking hardware shaft.

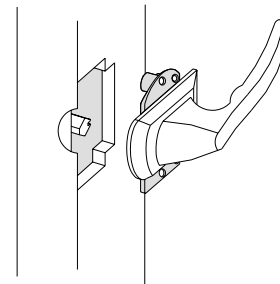

3. Fasten Assembly into place by using the 6x32 machine screws.

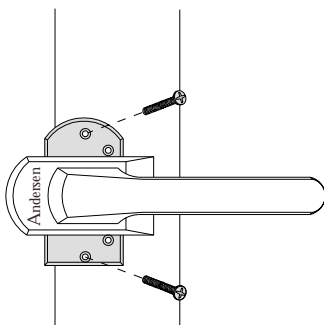

4. Pilot drill 1/8" x 1" deep holes and secure base plate to sash using No. 8x1" wood screws provided. Reset excutcheon plate to upright position. Assembly is complete.

